

Approved  YES  NO

Approved By: \_\_\_\_\_

Date: \_\_\_\_\_

# MAXPRO

## STANDARD SYSTEM INCLUDES

- DIRECT DRIVE MOTOR, UP TO 12ips OPENING SPEED
- PLC PROGRAMMABLE CONTROLLER
- SBR RUBBER CURTAIN - BLACK
- STEEL GUIDES - GALVANIZED
- BREAKAWAY BOTTOM BAR
- RUBBER EDGE
- LINTEL BRUSH SEAL

## MECHANICAL / ELECTRICAL OPTIONS

- EPDM RUBBER - BLUE
- EXTERIOR HOOD & MOTOR COVER
- REFLECTIVE PHOTO EYE
- WIRELESS SAFETY REVERSING EDGE
- THRU BEAM PHOTO EYE
- NEMA 4 3-BUTTON STATION
- MOTION DETECTOR
- LOOP DETECTOR
- WIRELESS RECEIVER
- WIRELESS TRANSMITTER: QTY. \_\_\_\_\_
- FLANGE MOUNT DISCONNECT
- VINYL VISION PANEL: QTY. \_\_\_\_\_
- ROLL TUBE PROTECTION BARS

**ELECTRICAL CRITERIA:** CONTROL PANEL: PLC  
PRIMARY POWER SUPPLY : 460 V. 3 Phase

**NOTES:**

PROJECT:

DEALER:

DRIVE:  
Right Hand Drive



(484) 840 - 8500  
5 Crozerville Road | Aston, PA 19014

DRAWN	DATE	NAME

[Qty: 01] MaxPro  
\_ ft (W) x \_ ft (H)

CHECKED

Drawing Number

Rev. 0

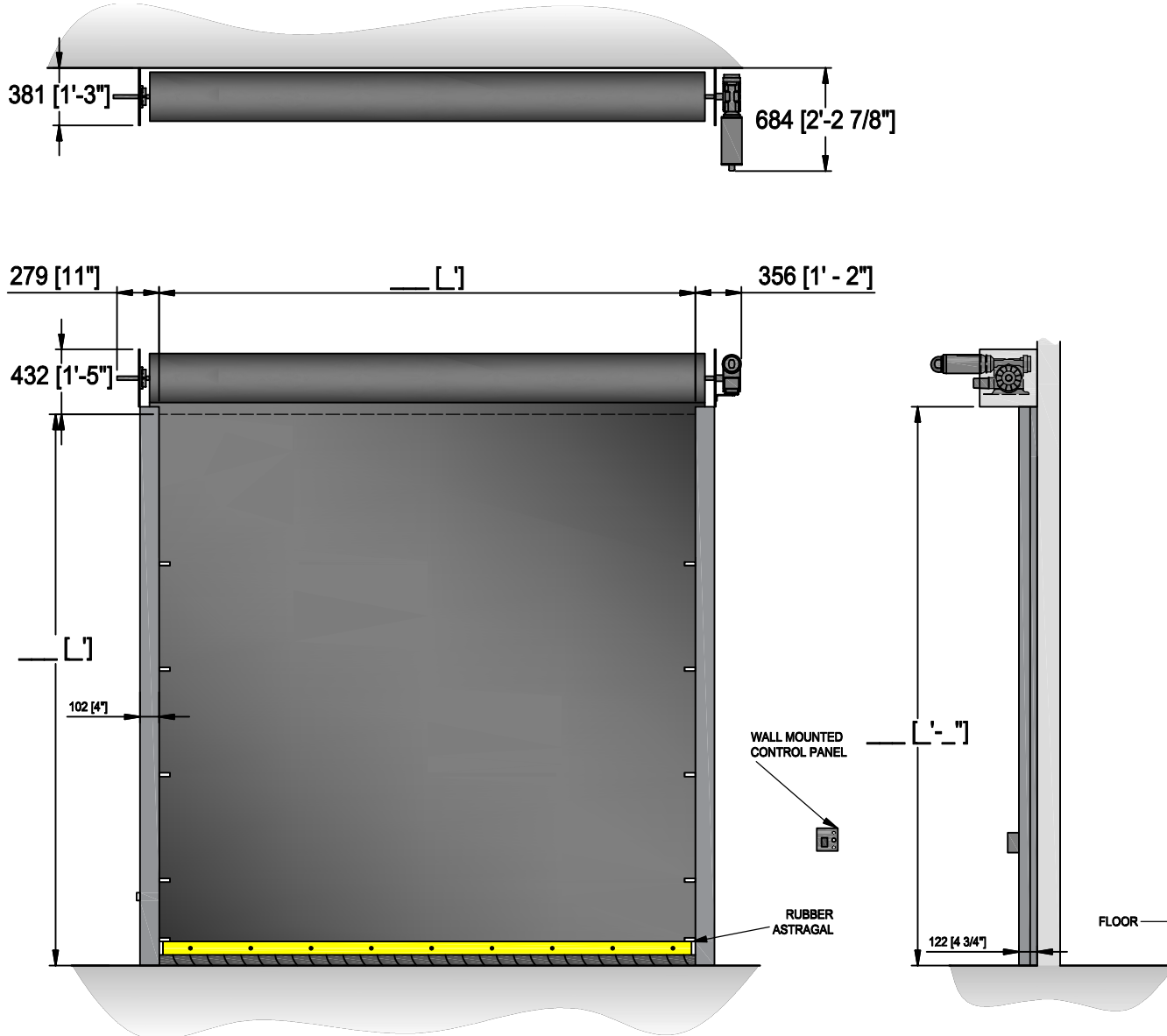

PERFORMAX: The design and engineering content shown remains PERFORMAX property and may not be copied in any way without written approval from the company.